

Installation Instructions (special tool needed: T-40/40mm Torque head screwdriver/bit)

1. Remove the bezel of the factory tailgate handle from its setting. Use a flat screwdriver to pry off (around the pin leg locations) the bottom edge of the bezel, then pull down the bezel to remove it.

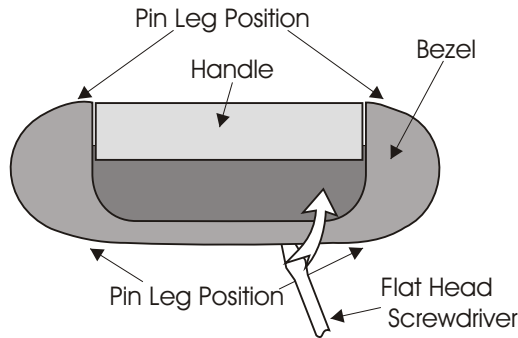

3. With the key in the lock, carefully align the hole on the mounting bracket with the hole on the inner wall of the tailgate, use the supplied screw to retain the lock to the wall, adjust the lock mechanism to the correct position, then firmly tighten the screw.

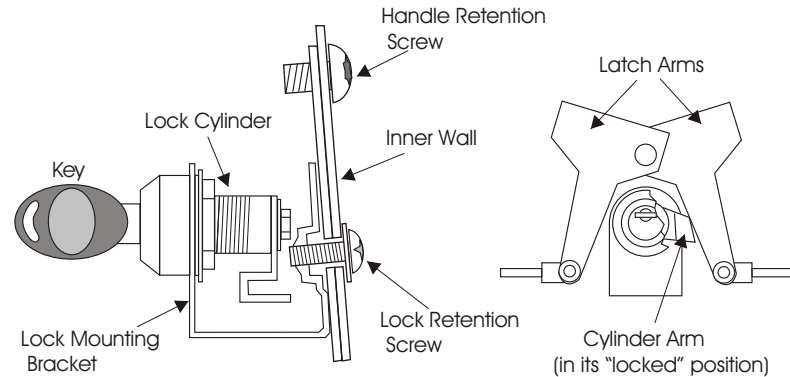

2. Locate the door latch holding bar of the tailgate (on the rear end of the bed wall for both side), use a T-40 torque bit to remove the bar and install a shield to protect the tailgate from being force opened. Locate the three tailgate handle retention screws on the inner wall of the tailgate, remove the screw on the bottom.

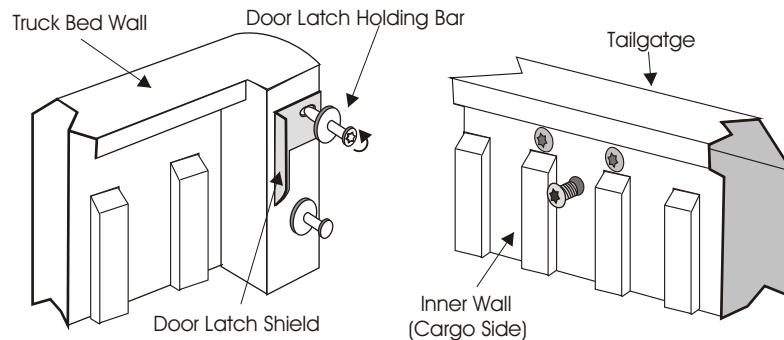

4. Remove the key from the cylinder, install the new bezel to the opening. Insert the top two pins into their setting, then press on the bottom two pins to pop the bezel into its setting.

Warning: The pin legs may be broken by improper installation. Make sure all the pin legs are in or aligned with their setting before pressing the bezel. In extremely cold weather condition, warm the bezel up before installing.

